

# CYCLOALKANES

Prepared By:

Dr. Maulik D. Vaja  
Associate Professor  
PhD



# CYCLOALKANES

# Introduction

- Cycloalkanes or cycloparaffins are saturated hydrocarbons in which the carbon atoms are joined by single covalent bonds to form a ring.
- The unsubstituted cycloalkanes form homologous series with the general formula  $C_nH_{2n}$

# NOMENCLATURE

- The name of an unsubstituted cycloalkane is obtained by attaching the prefix *cyclo*. to the name of the corresponding normal alkane having the same number of carbon atoms as in the ring.
- Substituent's on the ring are named, and their positions are indicated by numbers. The ring is numbered so that the carbons bearing the substituent's will have lowest possible numbers.

# Preparation of Cycloalkanes

**1. From Dihalogen Compounds:** Suitable dihalogen compounds on treatment with sodium or zinc give corresponding cycloalkanes.

This reaction is an extension of Wurtz Reaction and may be regarded as an internal Wurtz Reaction

# Preparation of Cycloalknes

- From Dihalogen Compounds

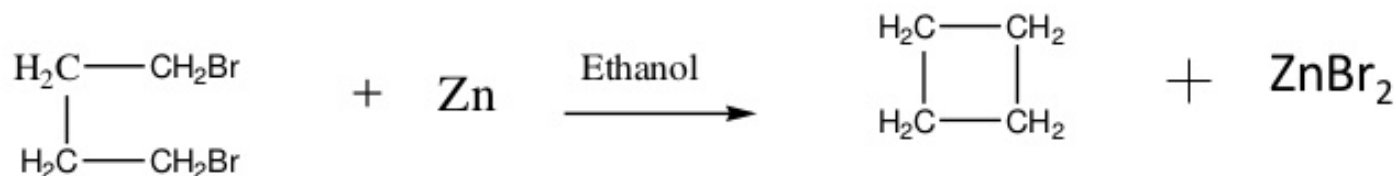
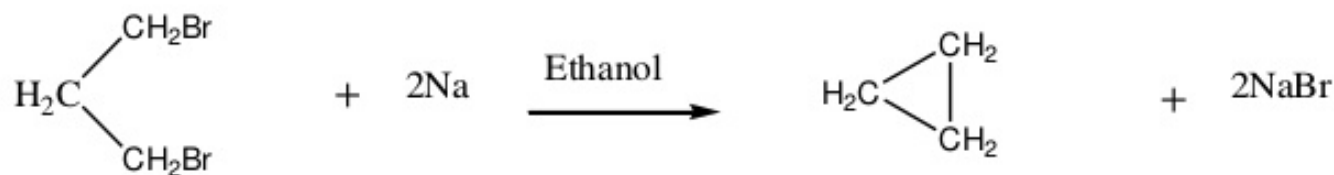

# Preparation of Cycloalknes

## 2. From Calcium or Barium salts of Dicarboxylic acid:

- When the calcium or barium salt of adipic, pimelic, or suberic acid is heated, a cyclic ketone is formed.
- Cyclic ketones may be readily converted into the corresponding cycloalkanes by means of the *Clemmensen reduction*

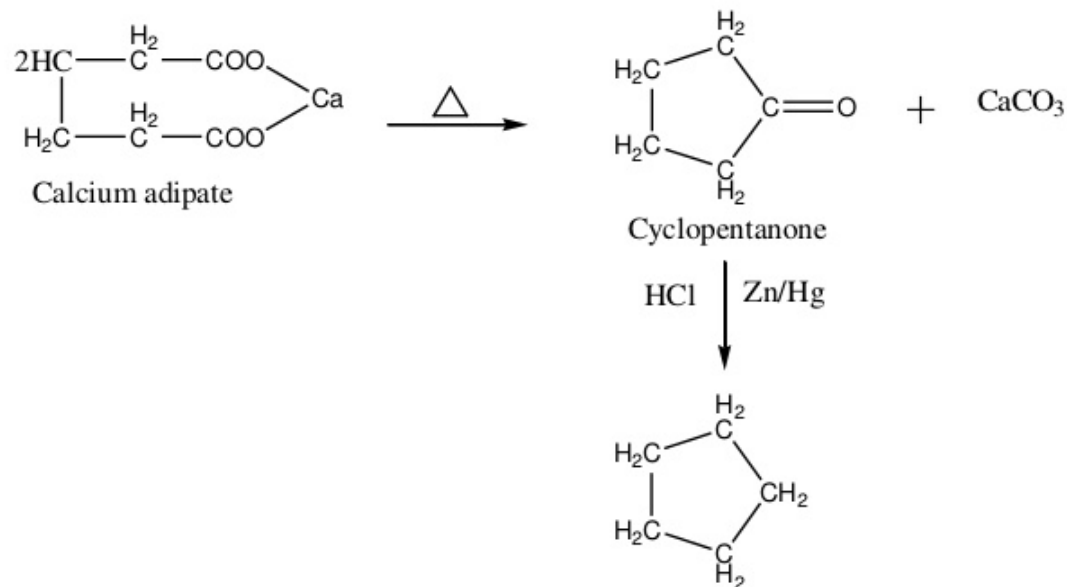

# Preparation of Cycloalkanes

## 3. From Esters of Dicarboxylic acids:

- The diester of adipic, pimelic, or suberic acid when treated with sodium undergoes intermolecular acetoacetic ester condensation and  $\beta$ -ketoester is formed.
- The  $\beta$ -ketoesters on hydrolysis give corresponding cyclic ketones.
- Cyclic ketones on reduction yield the corresponding cycloalkanes.



# Preparation of Cycloalkanes

- 3. From Esters of Dicarboxylic acids:

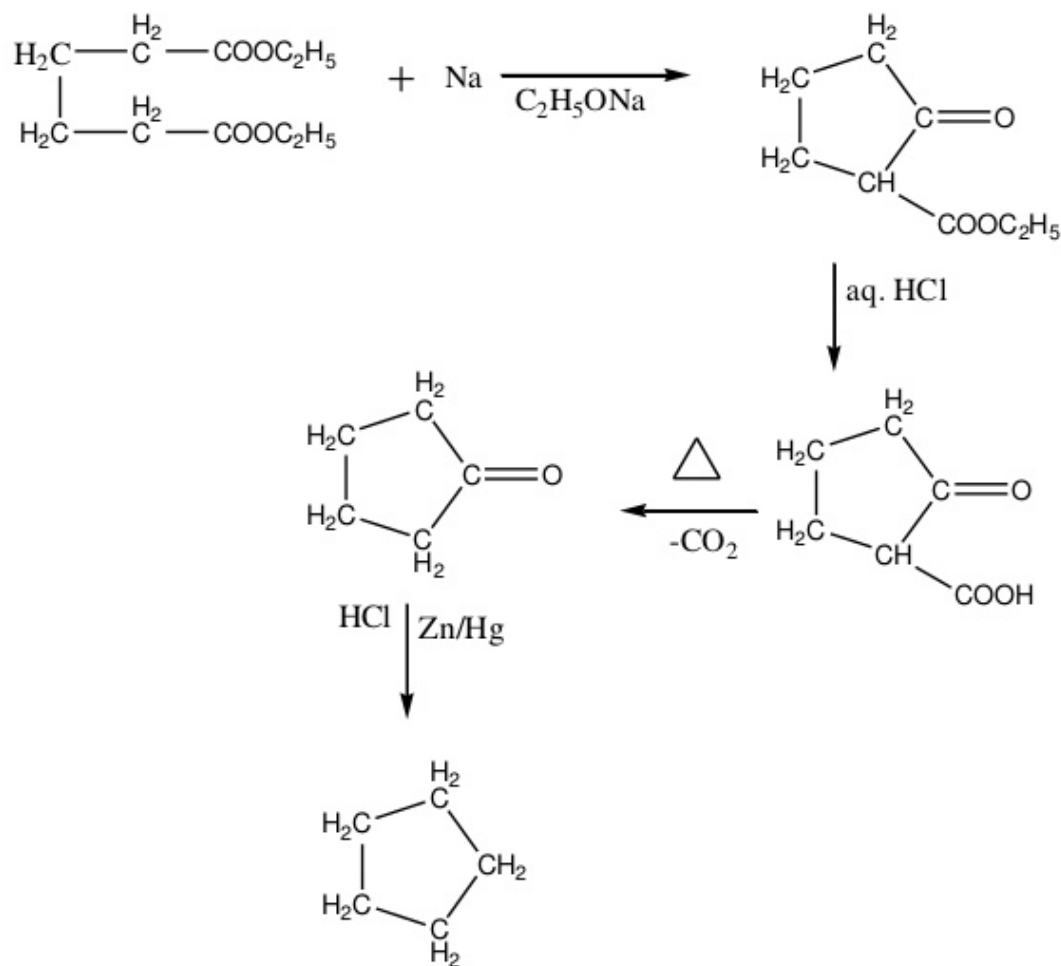

## Preparation of Cycloalknes

4. From Aromatic Compounds: Benzene may be catalytically hydrogenated at elevated temperature and pressure to yield cyclohexane.

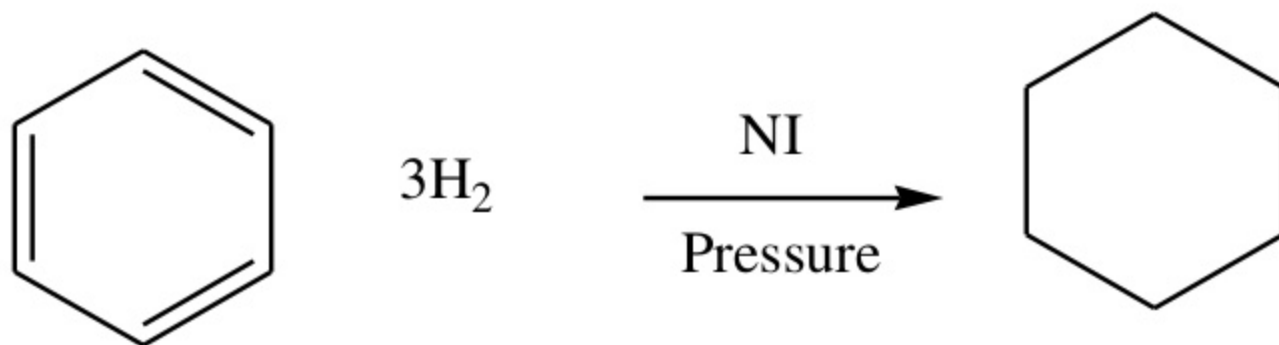

# PHYSICAL PROPERTIES

- (1) Cyclopropane and cyclobutane are gases at ordinary temperatures; the remaining cycloalkanes are liquids. Their melting points and boiling points show a gradual rise with the increase in molecular weight.
- (2) They are all lighter than water; the series has a limiting density of less than 0.9.
- (3) They are insoluble in water but are soluble in organic solvents such as ethers and alcohols

# Reactions of cycloalkanes.

- 1. Addition of  $\text{Cl}_2$  and  $\text{Br}_2$ :** Cyclopropane reacts with  $\text{Cl}_2$ , and  $\text{Br}_2$  at room temperature and in the absence of diffused sunlight to produce 1,3-dichlorocyclopropane and 1,3-dibromocyclopropane respective

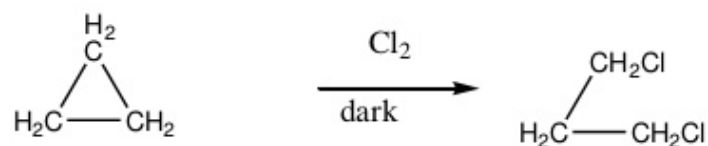
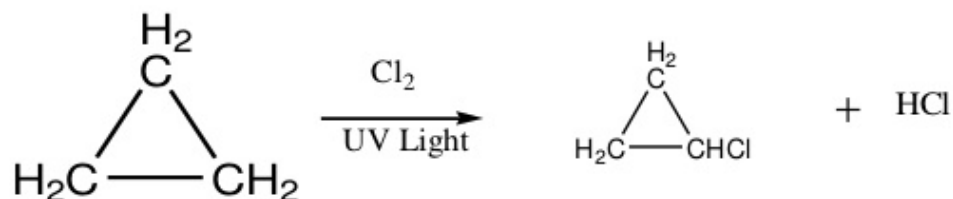

# Reactions of cycloalkanes.

## 2. Addition of HBr and HI:

Cyclopropane reacts with HBr and HI to give 1-bromopropane and 1-iodopropane.

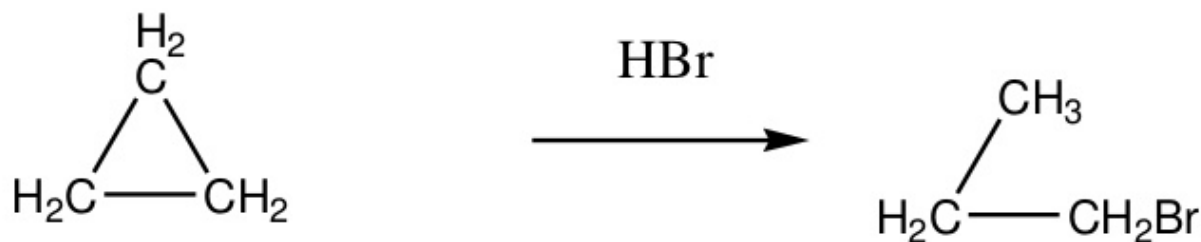

# Reactions of cycloalkanes.

## 3. Addition of Hydrogen; Catalytic Reduction.

- Cyclopropane and cyclobutane react with hydrogen in the presence of a nickel catalyst to produce propane and n-butane respectively.

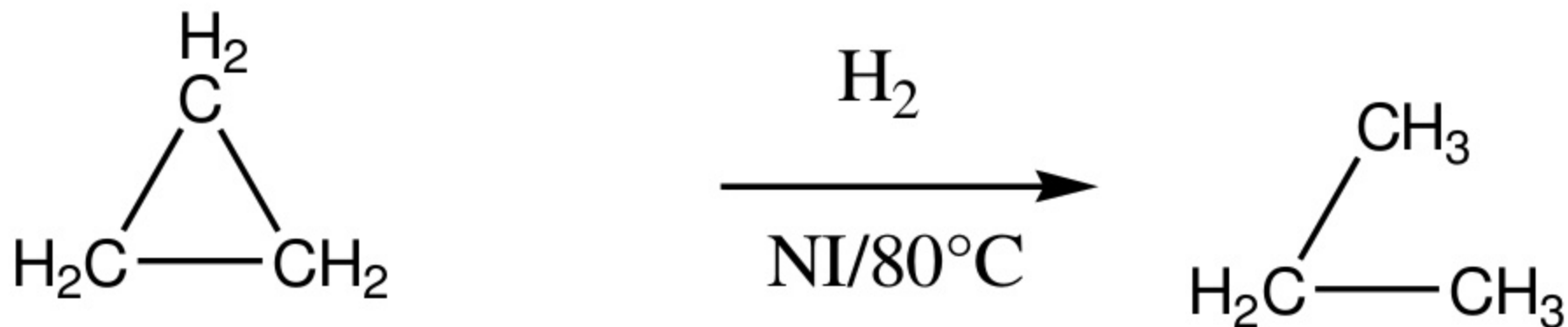

# *Historical Background on cyclohexanes*

1858 - Kekule and Couper -Tetravalence of Carbon

1874 - van't Hoff and LeBel - Tetrahedral Carbon

1885- Baeyer - Planar Cycloalkanes

- Polymethylene compounds (cycloalkanes) are strained.
- Since only one cyclohexane carboxylic acid is known, they must be planar.
- Cyclopentane is the least strained of the cycloalkanes.

1890 - Sachse - Strain need not exist in larger rings.

1918 - Mohr - x-ray analysis of diamond

Bond angle =  $109.5^\circ$  for  $sp^3$  hybridized tetrahedral carbon

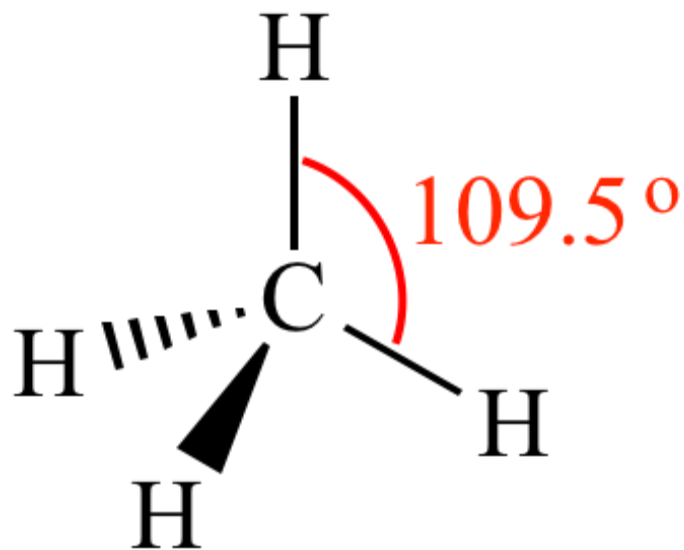



Strain theory, in chemistry, a proposal made in 1885 by the German chemist Adolf von Baeyer that the stability of carbocyclic compounds

Baeyer postulated that any deviation of bond angles from the normal tetrahedral value would impose a condition of internal strain on the ring

Baeyer observed different bond angles for different cycloalkanes and also observed some different properties and

- The bond angle is of  $109.5^\circ$  for carbon atom in tetrahedral geometry (methane molecule)

He proposed angle strain theory. The theory explains reactivity and stability of cycloalkanes.

If bond angles deviate from the ideal then ring produce strain

Higher the strain higher the instability. Higher strain produce increased reactivity and increases heat of combustion.

Baeyer proposed “any deviation of bond angle from ideal bond angle value ( $109.5^\circ$ ) will produce a strain in molecule. Higher the deviation lesser the instability.

**Baeyer's theory is based upon some assumptions as following.**

1. All ring systems are planar. Deviation from normal tetrahedral angles results in to instable cycloalkanes.
2. The large ring systems involve negative strain hence do not exists.
3. The bond angles in cyclohexane and higher cycloalkanes (cycloheptane, cyclooctane, cyclononane, etc.) are not larger than  $109.5^\circ$  because the carbon rings of those compounds are not planar (flat) but they are puckered.

# STABILITY OF CYCLOHEXANES - BAEYER STRAIN THEORY

**The bond angle in cyclopropane is  $60^\circ$ .**

- The normal tetrahedral bond angle value is  $109.5^\circ$ .
- That is why, deviation = (normal tetrahedral bond angle) – (actual bond angle)
- Deviation =  $109.5^\circ - 60 = 49.5^\circ$ .

**The bond angle in cyclobutane is  $90^\circ$ .**

- The normal tetrahedral bond angle value is  $109.5^\circ$ .
- That is why, deviation = (normal tetrahedral bond angle) – (actual bond angle)
- Deviation =  $109^\circ 5' - 90 = 19.5^\circ$ .
- Deviation for cyclopropane is  $49.5^\circ$
- Deviation for cyclobutane is  $19.5^\circ$ .
- The deviation is higher for cyclopropane than cyclobutane therefore cyclopropane is more prone to undergo ring opening reactions.
- As a result of this, the strain is more in cyclopropane as compare to cyclobutane.
- It will make **cyclopropane less stable than cyclobutane. So, cyclopropane easily undergoes** ring opening reaction as compare to cyclobutane.

All carbon atoms are SP<sup>3</sup> hybridized. Expected bond angle = 109.5°

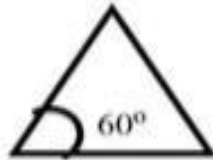

Deviation  
 $109.5^\circ - 60^\circ = 49.5^\circ$



Deviation  
 $109.5^\circ - 90^\circ = 19.5^\circ$   
Exists as puckered  
wing conformation

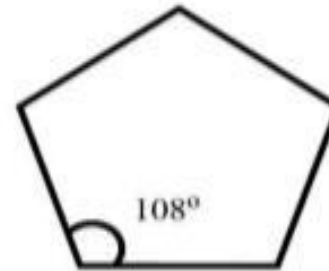

Deviation  
 $109.5^\circ - 108^\circ = 1.5^\circ$   
Exists as Open Envelope  
conformation

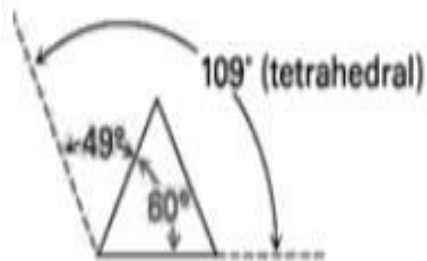

**Cyclopropane**

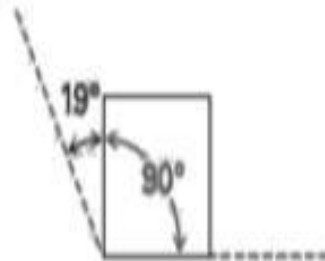

**Cyclobutane**

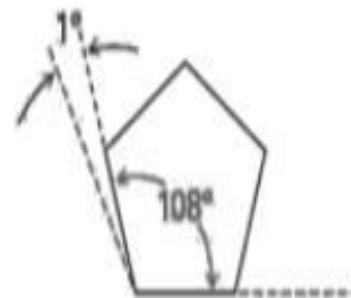

**Cyclopentane**

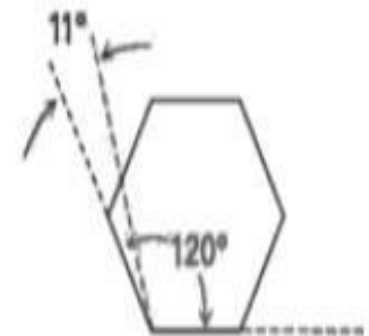

**Cyclohexane**

# Limitations of Baeyer strain theory

- Baeyer was not able to explain the effect of angle strain in larger ring systems.
- According to Baeyer cyclopentane should be much more stable than cyclohexane but practically it is reversed.
- Larger ring systems are not possible according to Baeyer as they have negative strain but they exist and are much more stable.
- Larger ring systems are not planar but puckered to eliminate angle strain.

# *Coulson-Moffitt Model*

Both are considers that cyclopropane ring from  $sp^3$  hybridized  $CH_2$  groups.

All  $sp^2$  hybridized are pointed  $22^\circ$  outward from imaginary the line connecting the nuclei, resulting in about 20% less effective overlap than the C-C bond of ethane.

For this reason, the bonds are often referred to as bent.

This bending is considered for angle strain.

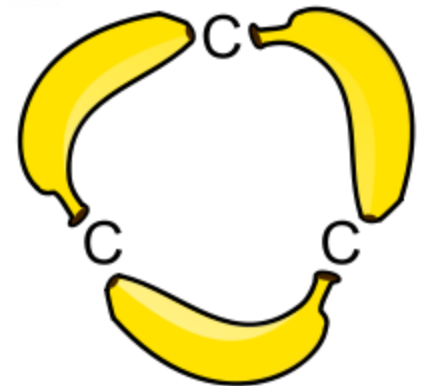
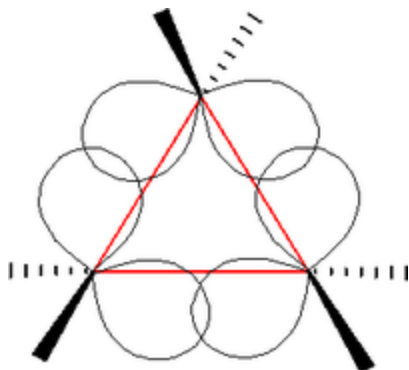

- C-C-C bond angle of  $60^\circ$
- Electron density found outside the internuclear axis, including electron density found in the center of the ring.
- Cyclopropane has a ring strain of 27.6 kcal/mol, only 1.4 kcal/mol more than cyclobutane despite its significantly reduced bond angles.

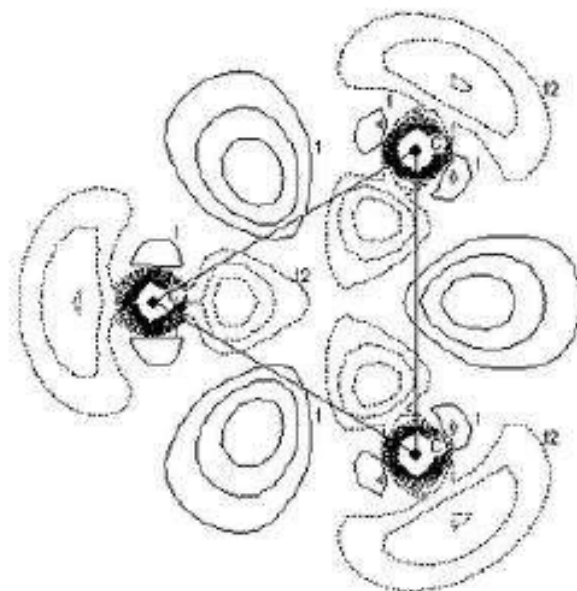

Cyclopropane Electron cloud



To satisfy the fact that the electron density is not on the internuclear axis the banana bond idea was applied. This idea is that the orbitals are angled towards one another and do not meet head on, thus forming a curved, banana shaped bond.

This reduces the overlap of the orbitals but makes the angle between orbitals  $104^\circ$ , far closer to the ideal angle. This was proposed in conjunction with an  $sp^5$  hybridization for the carbon atoms.

This explanation is informative but fails to explain the increased electron density in the center of the molecule or the ring strain anomaly.

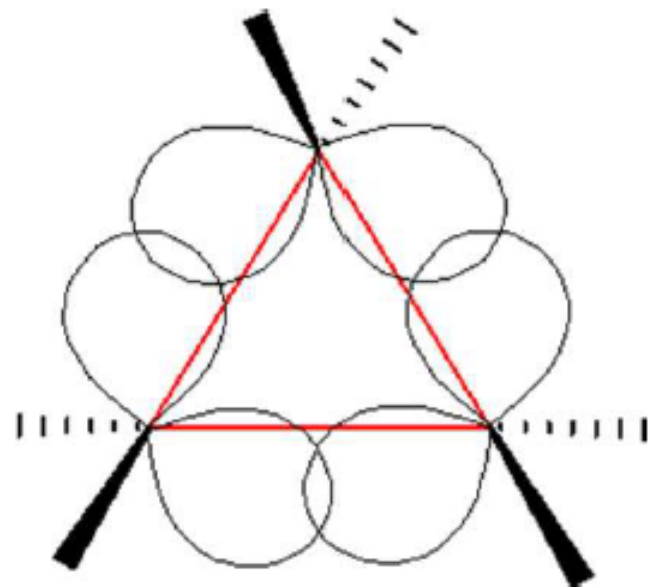

# SACHSE-MOHR THEORY OF STRAINLESS RING

- Sachse theory(1890)
- The carbon atom of cyclohexane and higher alkanes are not planar but assume strain free puckered configuration, in which each carbon retains its normal valency angle of  $109.5^\circ$
- Sachse constructed two models of cyclohexane called as boat and chair forms.



# SACHSE-MOHR THEORY OF STRAINLESS RING

- Mohr theory(1931)
- Mohr suggested the possibility of existence of two forms which readily undergo interconversion by rotation of single bonds involving negligible distortion of tetrahedral angles. Only 5kcal/mole energy is needed for their interconversion.

The two conformational isomers are in dynamic equilibrium and have not been individually isolated.

On the basis of theoretical and experimental evidence, it has been found chair conformation is more stable than boat form.

# SACHSE-MOHR THEORY OF STRAINLESS RING

- The ratio of chair to boat conformation is about 1000:1
- Cyclohexane shows that the twelve hydrogen in the chair conformation divided into two categories
- Six hydrogen are point up called as axial hydrogen
- Other six hydrogen lie along the equator called as equatorial hydrogen
- When the chair conformer is converted into boat conformer, each equatorial hydrogen becomes axial and vice versa.

## Conformations of Cyclohexane

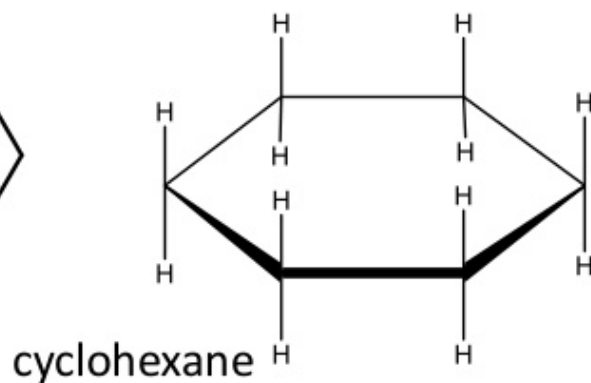
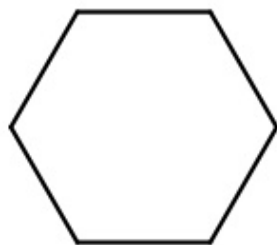

**Chair**  
conformation of  
cyclohexane

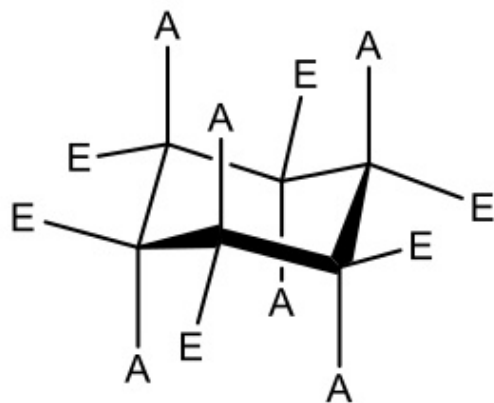

**Boat**  
conformation of  
cyclohexane

